

An Evolutionary Integration Approach using Dynamic CORBA in a typical Banking Environment

Markus Pohlmann , Marc Schönefeld

**GAD eG
Münster
Germany**

- The Context
- Past & Present: The current BCI-Environment (non CORBA)
- Future: The ServiceBus-Architecture
- Built-In Design Patterns
- Conclusions & Further Enhancements

The Company

- Headquarters: Muenster
 - Weseler Straße, 48163 Muenster
- Branches: Koblenz and Lehrte
 - Ernst-Sachs-Straße 12, 56070 Koblenz
 - Raiffeisenstraße 12, 31275 Lehrte
- Additional Locations: Hamburg, Oldenburg
 - Rosenstraße 8, 20095 Hamburg
 - Sandkruger Straße, 26133 Oldenburg

The Company

- IT Service Provider and Data Processing Center
 - for approx. 640 Volksbanks and Raiffeisenbanks as well as Spar- and Darlehnskassen

- Software Development Company
 - for the co-operative banks (e.g. WGZ-Bank, DZ BANK, WL-Bank)

Dynamic CORBA in a typical Banking Environment Services



- BB3 – one level, process-oriented retail banking dialog system
 - Supports a large number of legally independent, individual banks
- ZIS information system for the central banks WGZ-Bank and DZ BANK

■ Distributed devices:	120.846
■ Administered accounts:	30.2 M
■ Bookings 2001:	1.708 M
■ Transactions 2001:	7.145 M
■ ATM withdrawals:	174.6 M
■ Self-service account statements:	202.5 M
■ Self-service accounts with Internet access:	837.135

Dynamic CORBA in a typical Banking Environment

Choice of a Migration Strategy

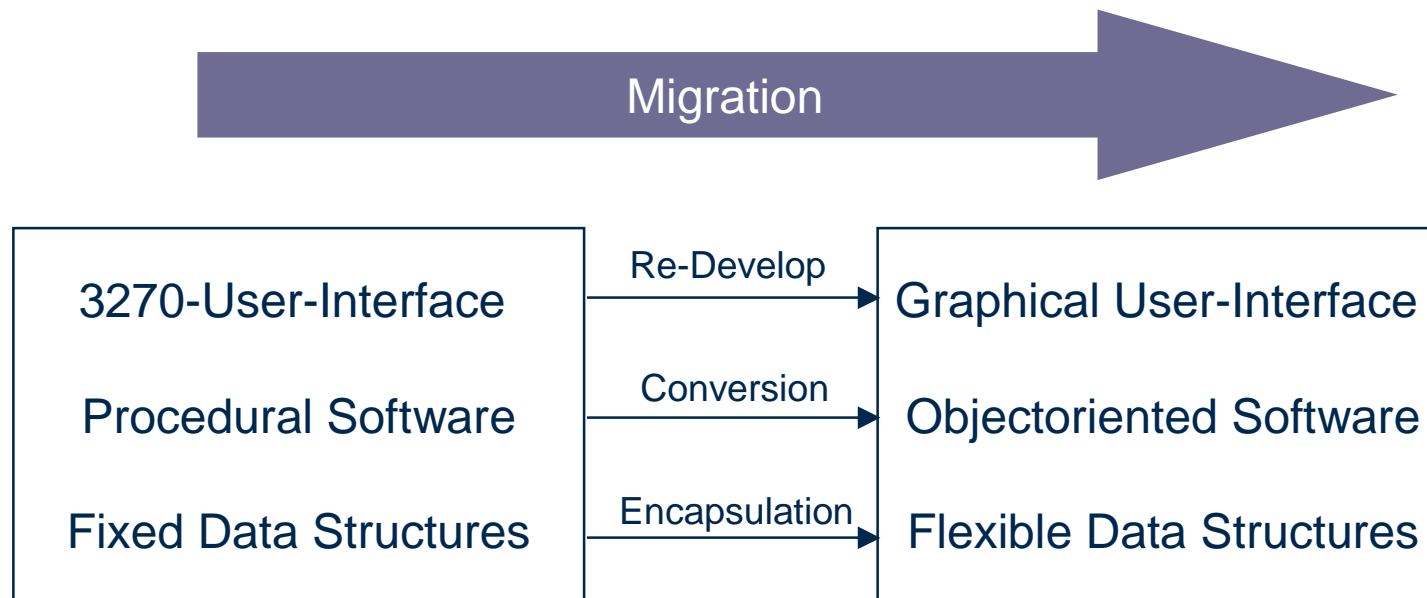

(Sneed, 1997)

■ ReUse

- Base Business Services existing in Backend
- Metadata already documented in Repository

Dynamic CORBA in a typical Banking Environment

The purpose of the Servicebus: Integration

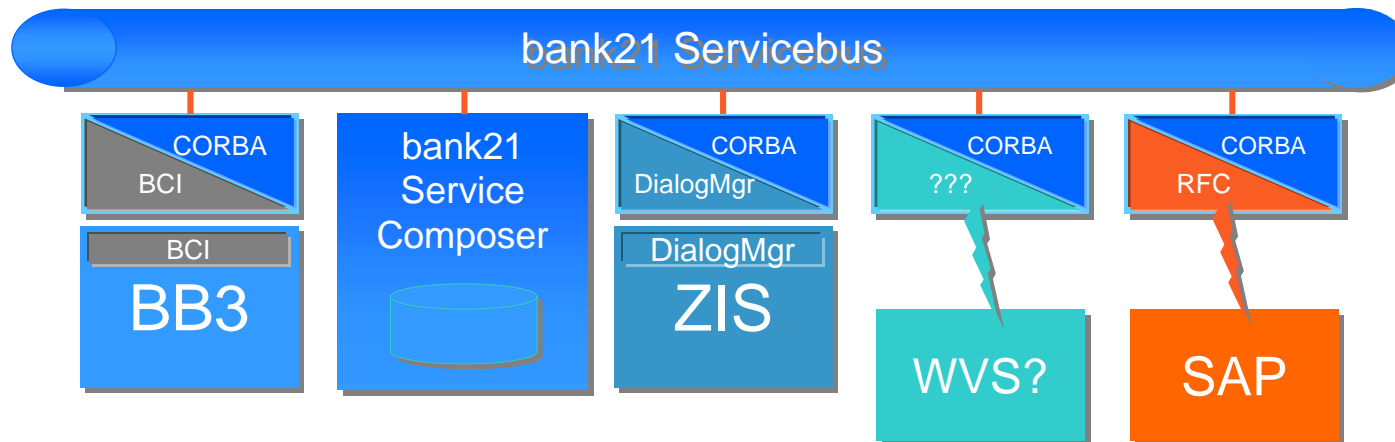

Dynamic CORBA in a typical Banking Environment Infrastructure for the Servicebus

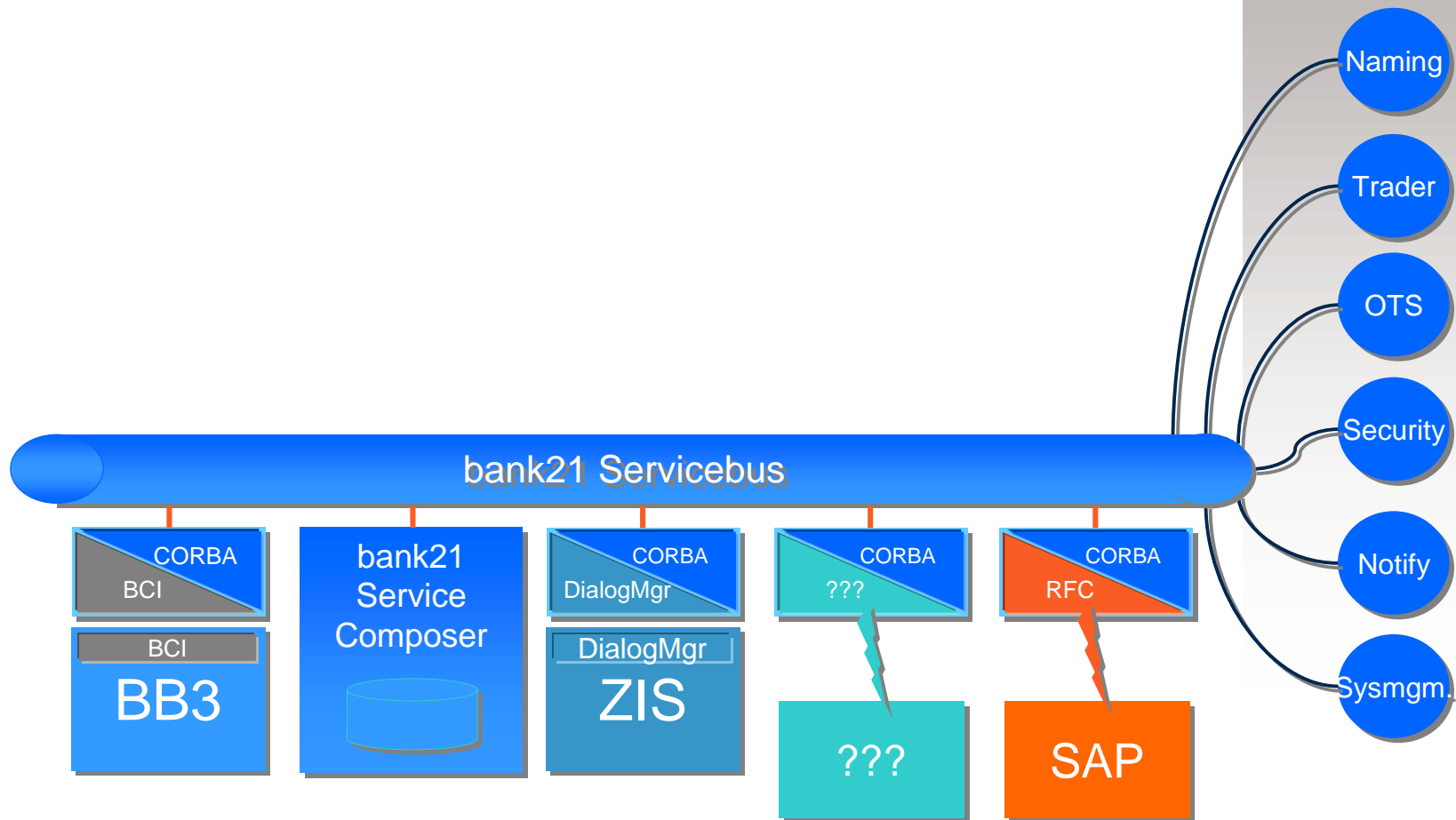

Dynamic CORBA in a typical Banking Environment

Technical Base Functions of the Servicebus

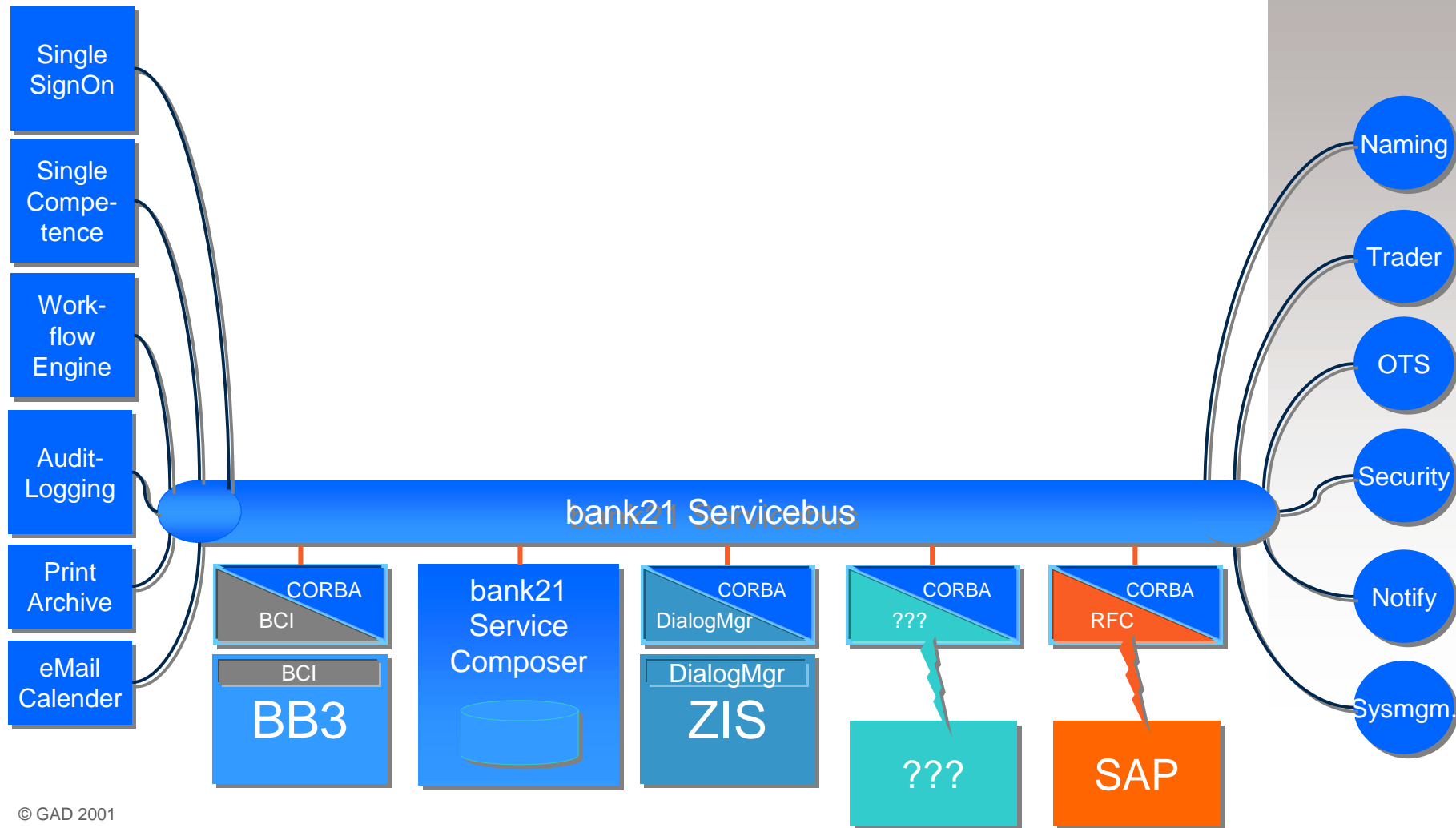

Dynamic CORBA in a typical Banking Environment

Process- and business components

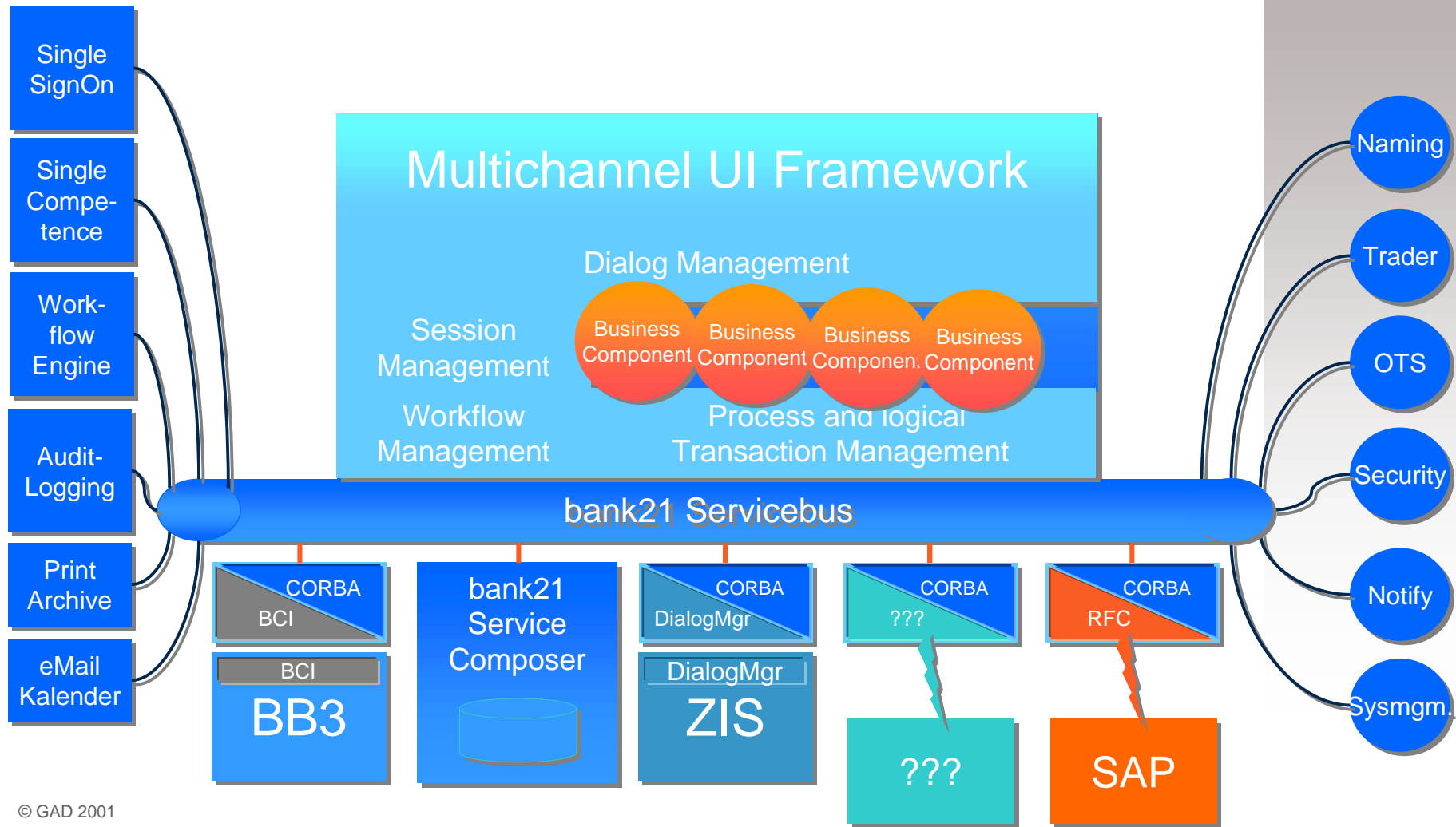

Dynamic CORBA in a typical Banking Environment

Plugins for Multiple Channels

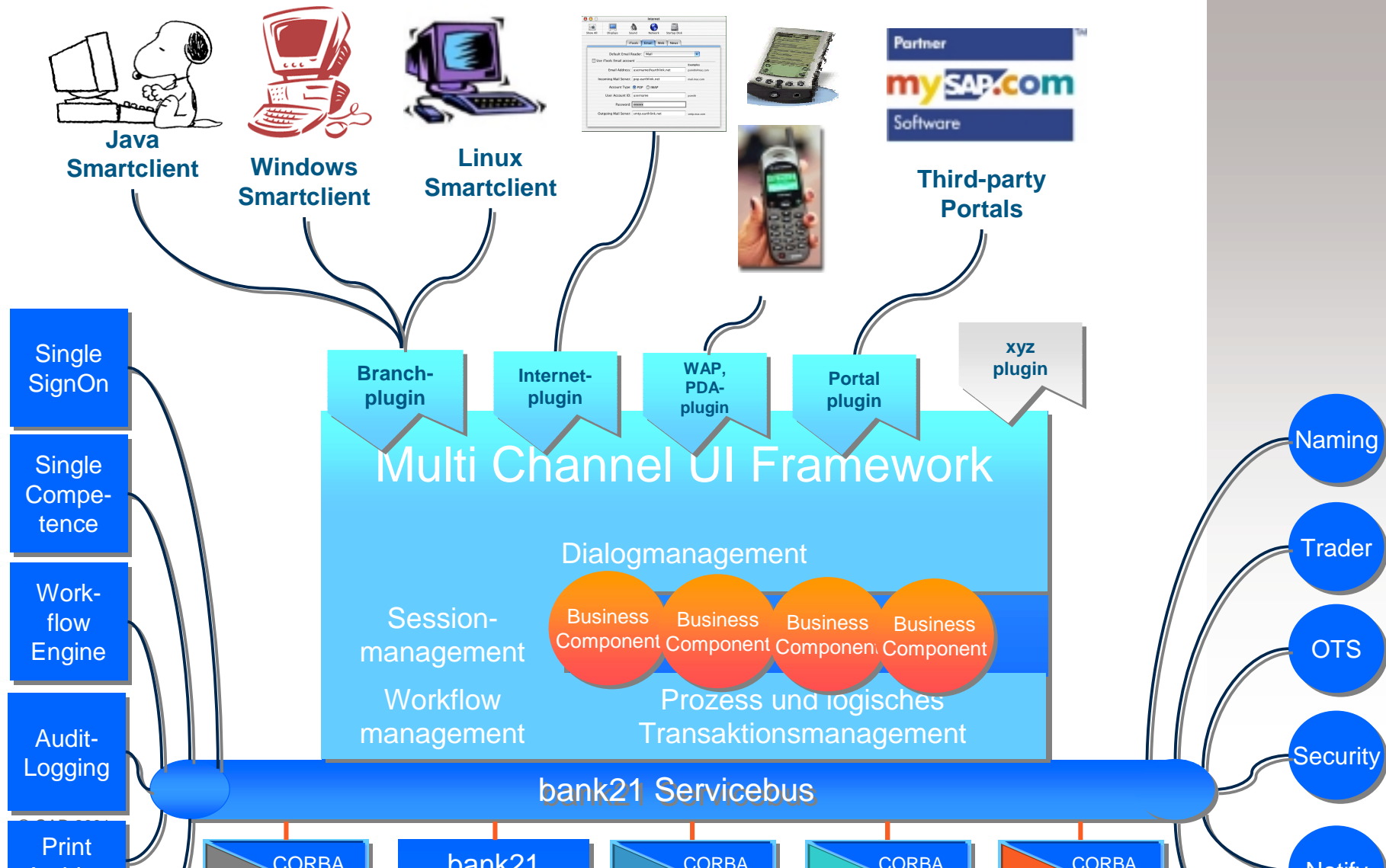

- Build a integrated, high-available and scalable Servicebus-Infrastructure
 - Integrated
 - Available 365 * 24 * 7
 - Secure
 - Scalable
- Limit the range of used technologies to a few, but efficient solutions
- Prefer semantic-rich and type-safe middleware in favor of byte-level-middleware

The current scenario

Dynamic CORBA in a typical Banking Environment

Current Productive BB3-Architecture

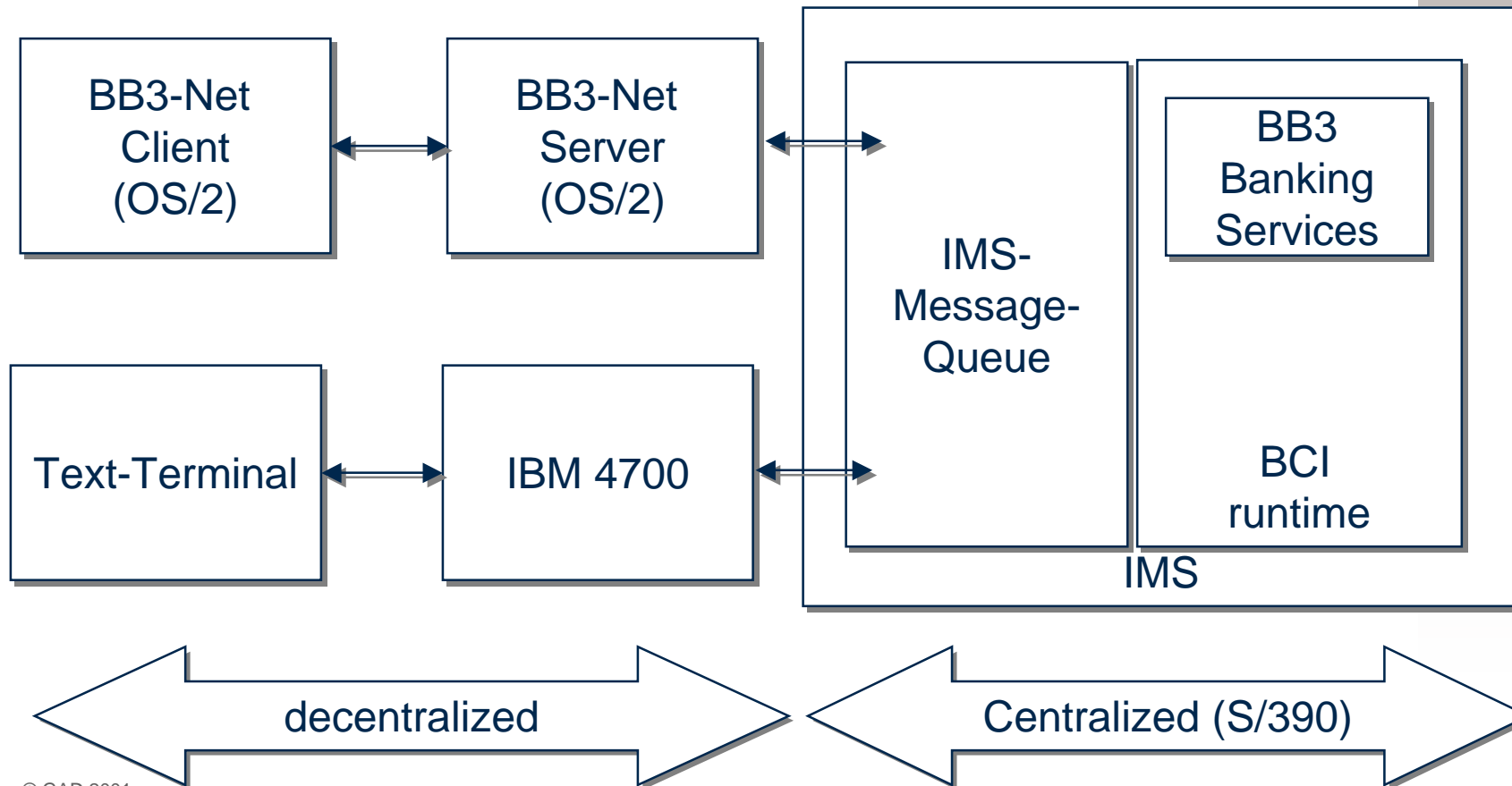

Dynamic CORBA in a typical Banking Environment

Target Productive BB3-Architecture

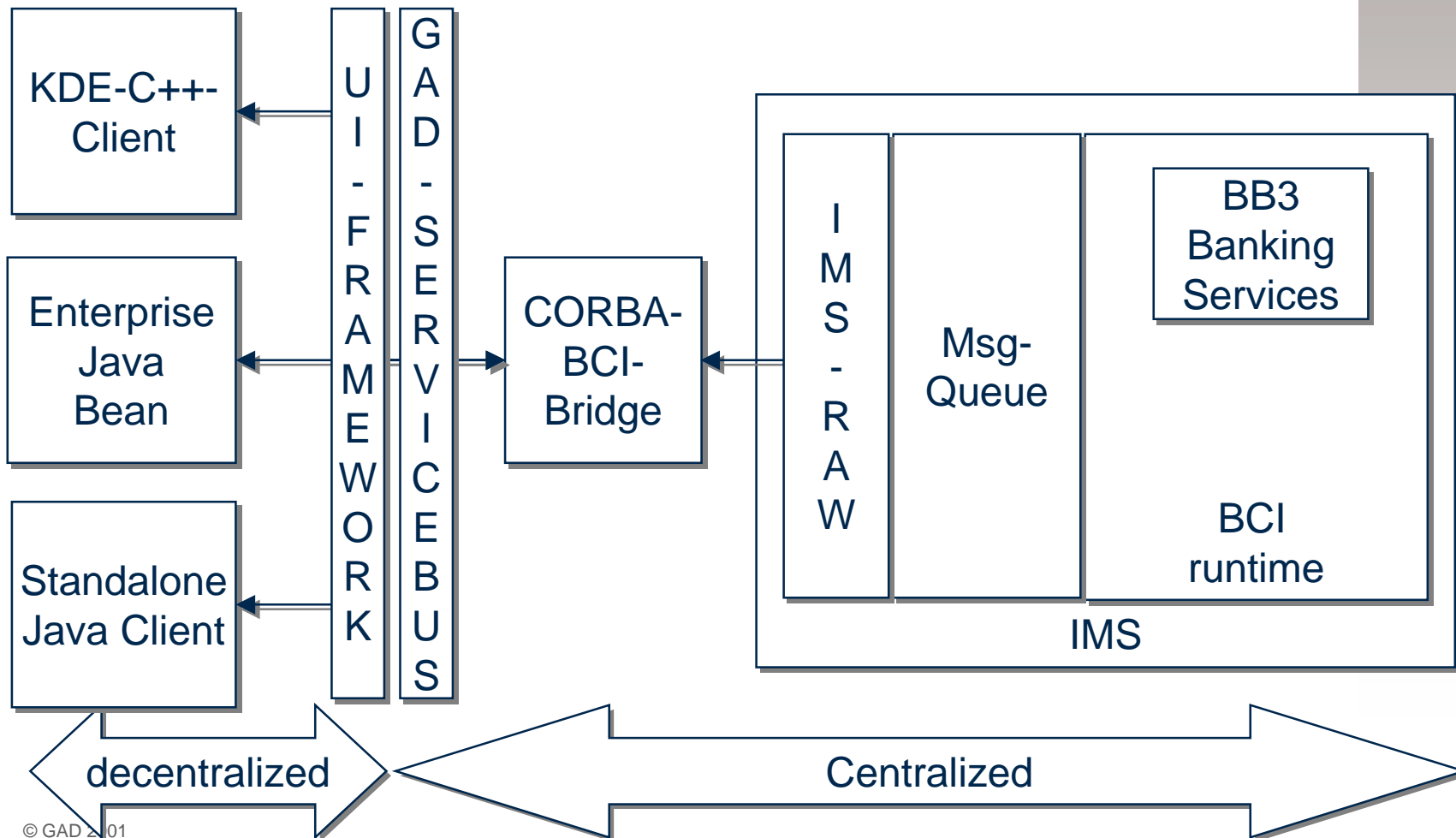

Architectural Design

Dynamic CORBA in a typical Banking Environment

Implementation overview

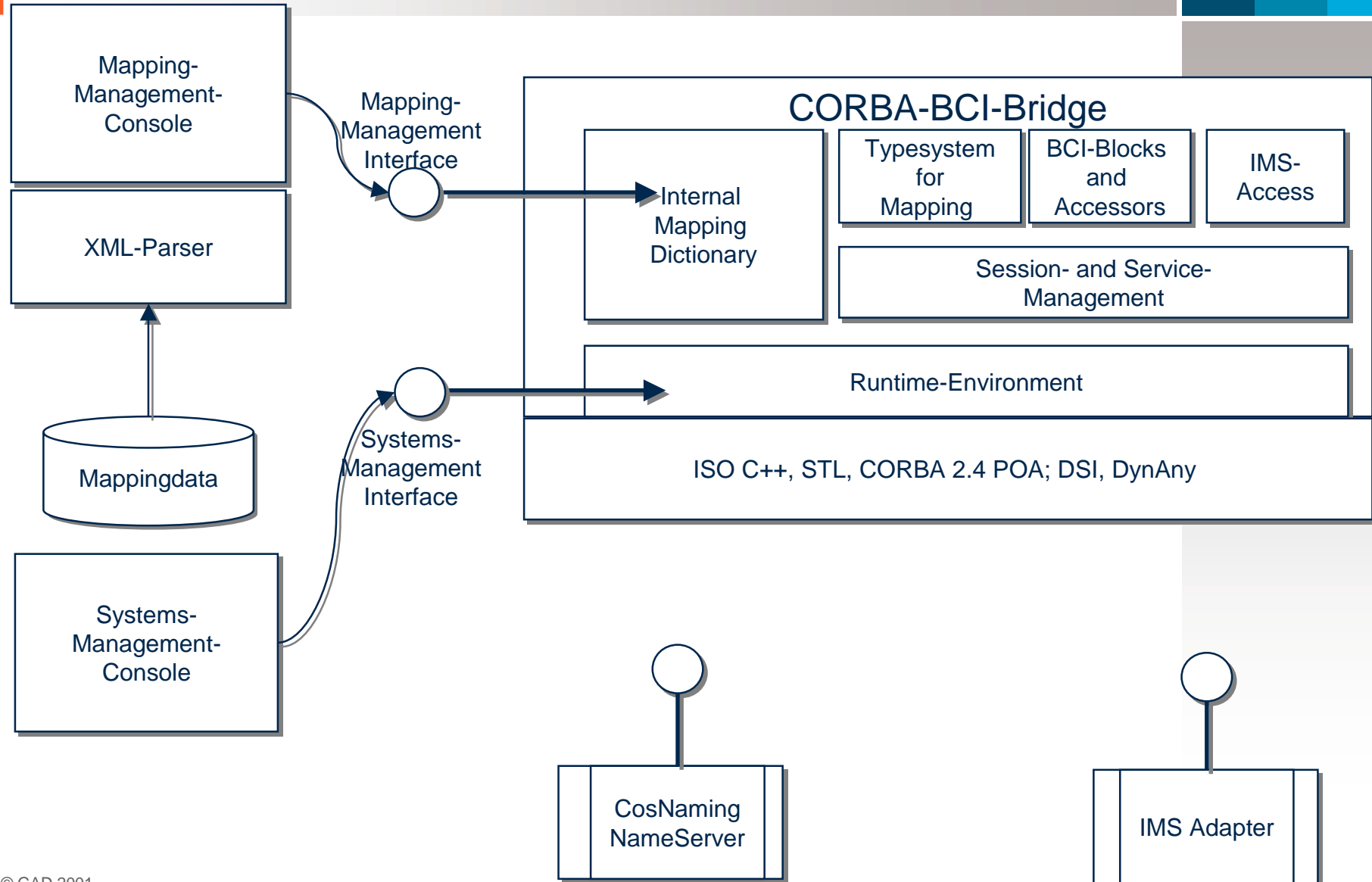

Dynamic CORBA in a typical Banking Environment

Design- und Runtime Processes

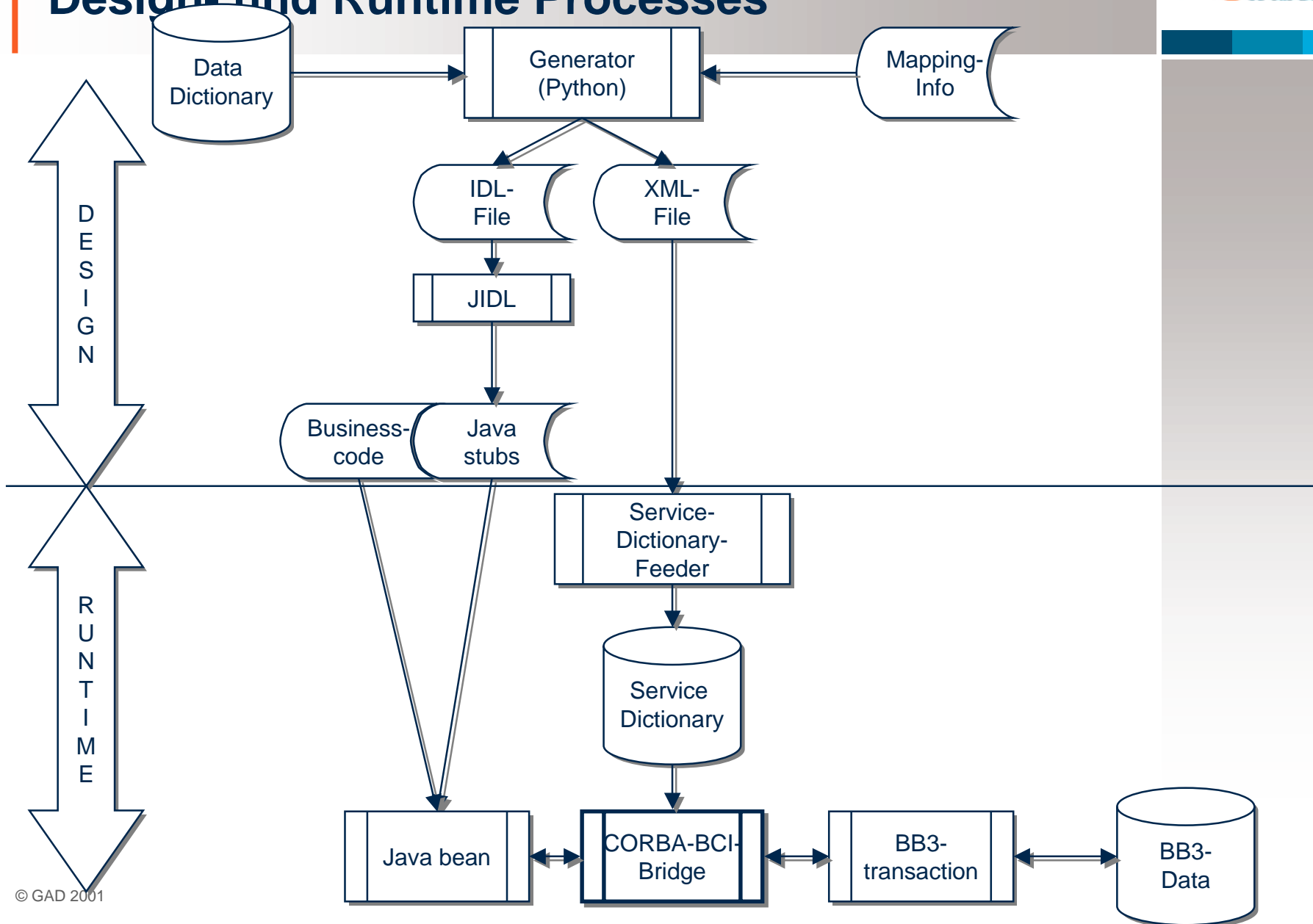

Built-In Patterns

Dynamic CORBA in a typical Banking Environment

Supported BCI-Usage-Pattern

1:1-Mapping
Simple
Methods

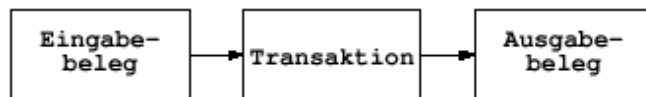

1:n-Mapping

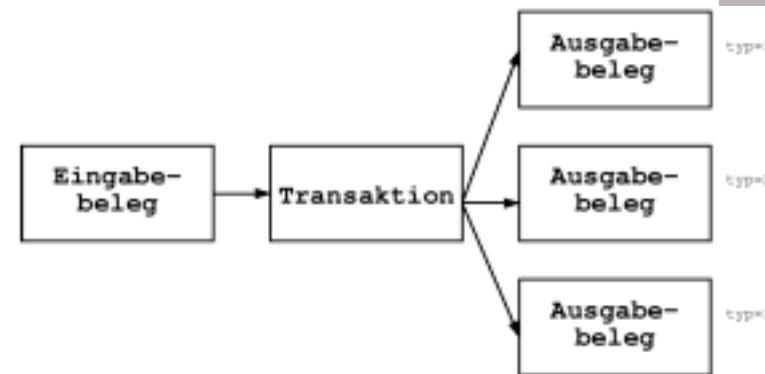

1:0-Mapping are void
methods

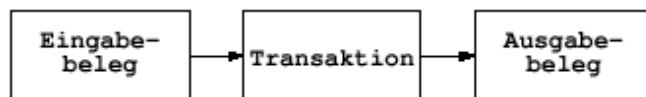

Iterator for
tabular data



Base Patterns: Simple Methods



Union Method

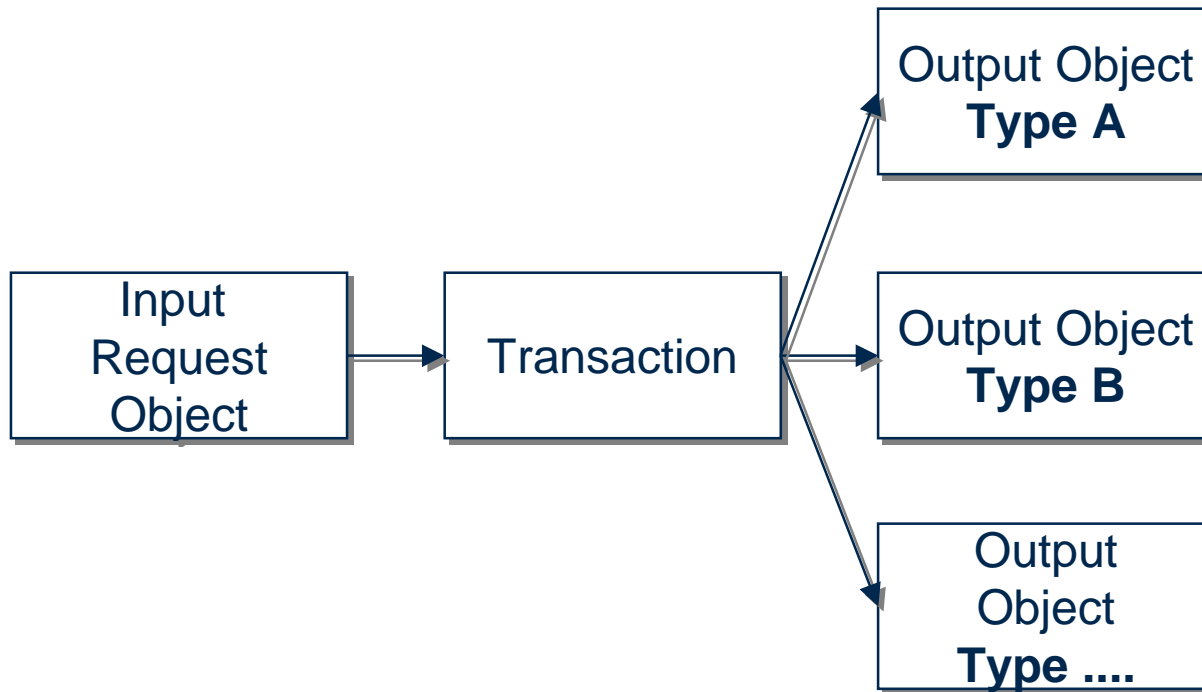

Void-Methods

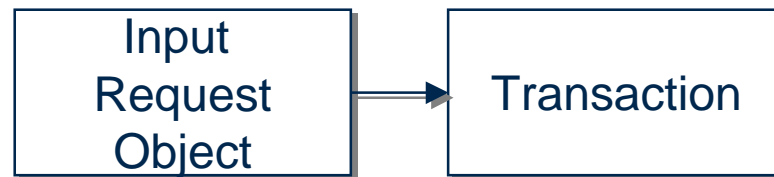

Iterator Methods

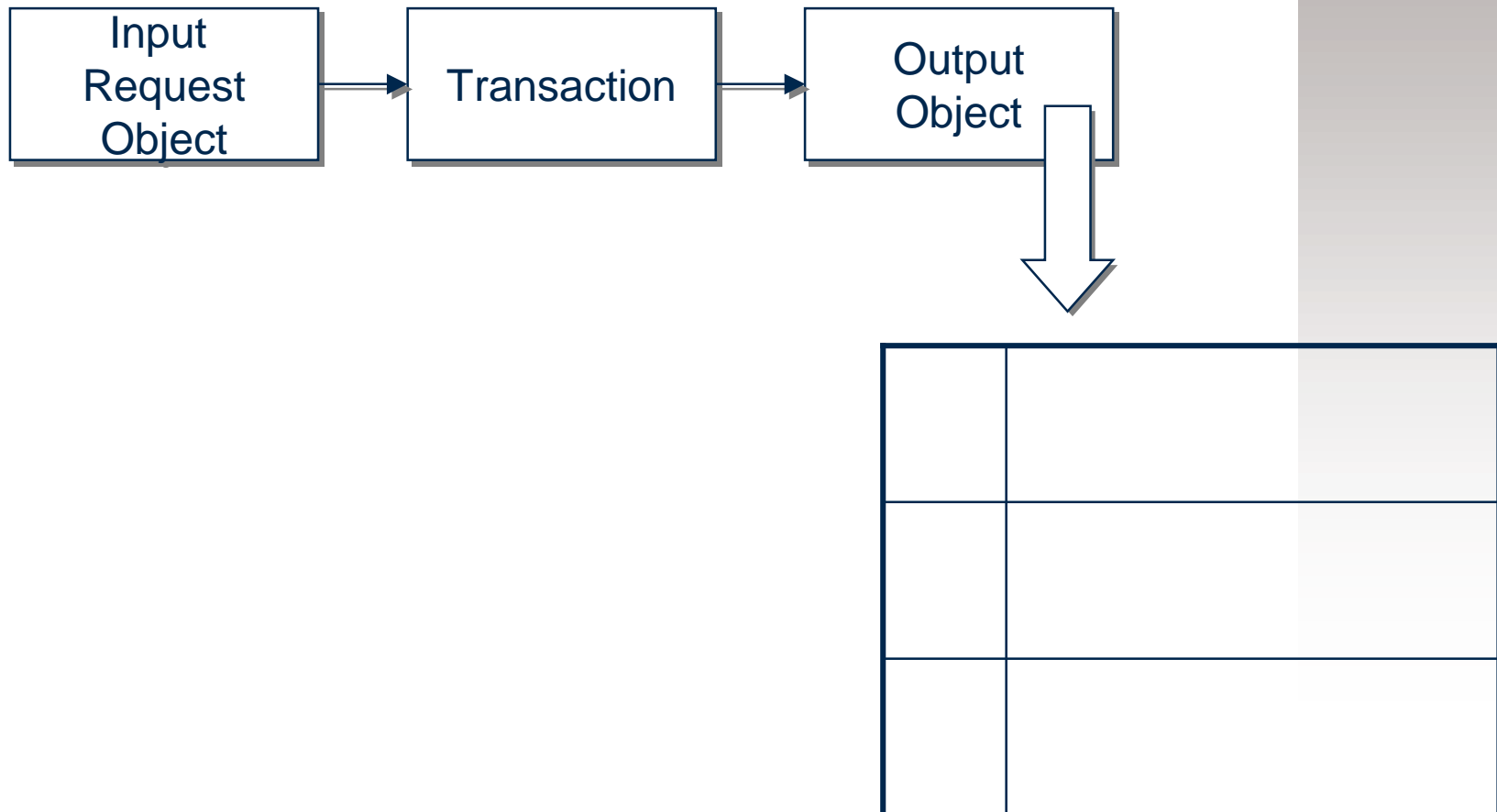

Conclusions and Further Enhancements

- Dynamic CORBA is a good base for semantic rich legacy integration
- Type-safe IDL-contracts enhance software quality

- Establishing Service-Enabling as leading Software Development Paradigm
 - Refactoring of the Back-End transactions
- Security Integration (CORBA 2.6)
- Role-Based Access Control (PKI)